



Ultrastar DC ME200 Memory Extension Drive,  
NVMe 2.5-inch U.2 and PCIe AIC HH-HL

## Highlights

- Enables scaling of system memory, typically up to 24TiB<sup>1</sup> per 1U server and 96TiB in 4U servers
- Delivers DRAM-like performance for key enterprise applications and workloads\*
- Transparent to existing OS and applications
- Promotes server consolidation
- Fits most industry-standard server models

## Applications

- Business Analytics
- Data Warehousing
- Application Caching
- Server Virtualization
- Container-Based Applications
- Genomics & AI Research
- Real-Time Analysis
- Cloud Services and SaaS
- IoT, Time-Series Analysis

## Memory Expansion for the Data Center

The digital economy has created significant demands for both real-time and batch processing of large data sets. IT organizations across the world are leveraging in-memory computing to drive superior application performance and obtain meaningful insights through the use of advanced business analytics.

However, in-memory computing can become bottlenecked by set limitations on the amount of memory available to the server, as well as prohibitive DRAM pricing.

Ultrastar® DC ME200 Memory Extension Drive can be used to scale existing system memory, promote server consolidation, and reduce the complexity of splitting large multi-TB data sets across multiple servers. Ultrastar memory drive provides applications with large amounts of system memory at a fraction of the cost of DRAM. Advanced software algorithms work to maintain near DRAM-like performance across a variety of applications, especially targeting highly parallel workloads with high numbers of transactions. Once installed, the solution is transparent, requiring no changes to the existing OS and application stacks.

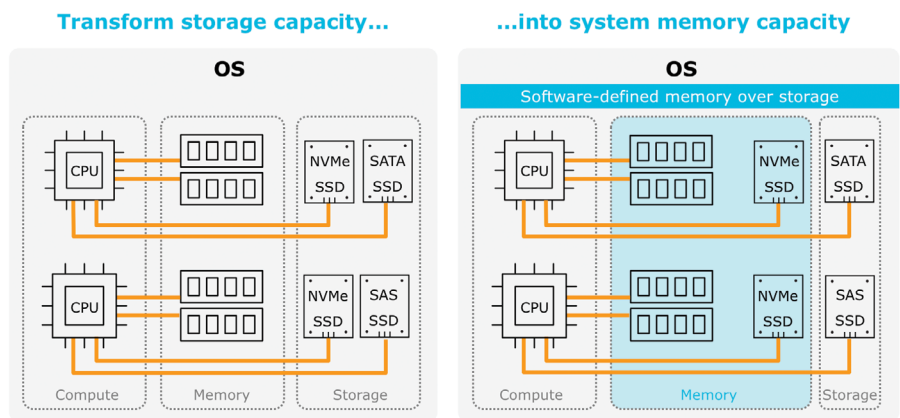

Figure 1: Software-defined Memory Extension utilizing Ultrastar memory drive with Western Digital Memory Extension

## Dramatically Scale System Memory

Web application caching in particular requires large amounts of system memory to quickly ingest and analyze vast streams of data from Internet users, transaction events, and IoT devices. High concurrency environments, such as virtualized servers and container-based applications, are prime examples where memory usage can quickly outpace processing capabilities, requiring expensive additional scale-out servers to house the extra memory and virtual machines.

Ultrastar memory drive allows for the transparent expansion of system memory, enabling larger data sets to be used for analytics computations, more data to be stored in front-end web caches, and overall more work that can be accomplished within each server.

## Memory Expansion Example:

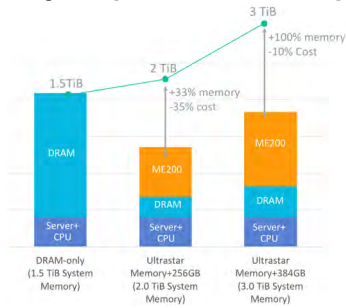

Figure 2: Scaling system memory with Ultrastar memory drive; based on current DRAM spot pricing (Fall 2018).

## Baseline

1U, 2-socket server  
24x 64GiB DRAM DIMMs  
1.5TiB total system memory

## Config-A (1:8 memory extension)

Config-A (1:8 memory extension)  
1U, 2-socket server  
16x 16GiB DRAM DIMMs (256GiB)  
2x 1TiB ME200 devices  
2TiB total system memory

## Config-B (1:8 memory extension)

1U, 2-socket server  
24x 16GiB DRAM DIMMs (384GiB)  
3x 1TiB ME200 devices  
3TiB total system memory

## Performance Example:

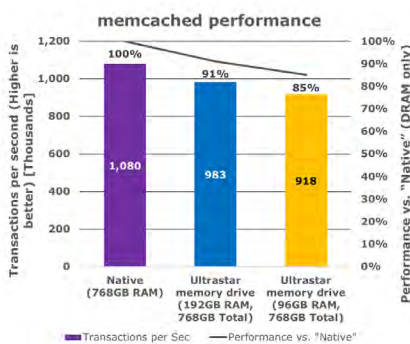

Figure 3: Performance comparison of Memcached based on internal testing. Results may vary based on system configuration, load, and other factors.

## Western Digital

5601 Great Oaks Parkway  
San Jose, CA 95119, USA  
US (Toll-Free): 800.801.4618  
International: 408.717.6000

www.westerndigital.com

## Use-Case Scenarios:

- Configuration A** in Figure 2 on the left shows that reducing DRAM from 1.5TiB to 256GiB and adding two 1TiB Ultrastar memory drive devices can reduce total system cost by 35% and provide applications with **33% more memory**.
- Configuration B** in Figure 2 shows that by reducing DRAM from 1.5TiB to 384GiB and adding three 1.5TiB Ultrastar memory drive devices, you can reduce TCO system cost by 10%, while providing applications with **100% more memory**.
- Both **Configuration-A and Configuration-B** in Figure 2 showcase how Ultrastar memory drive **enables server consolidation** by allowing for the increase in size of data sets that can be handled within a single server, thereby reducing the total number of servers, application licenses, and associated **OPEX and CAPEX** costs.
- Figure 3** is a performance example using Memcached, typically used in content caching applications. Total system memory as seen by the application in all three instances is 768GiB. The first bar represents the full amount of system memory in native DRAM. The second and third bars show the same workload run using less DRAM plus Ultrastar memory drive in a 1:4 memory extension ratio and 1:8 memory extension ratio. The application is able to maintain **91% performance\*** and **85% performance\*** respectively, compared to running in DRAM alone.

## Specifications

Memory Capacity <sup>1</sup>	1TiB, 2TiB, 4TiB
Recommended Expansion <sup>2</sup>	Scale system memory up to 8x DRAM: -Up to 24TiB in 2P servers (1U) -Up to 48TiB in 4P servers (2U) -Up to 96TiB in 8P servers (4U)
Recommended Configuration	One Ultrastar® memory drive device per socket
Supported Processors	Intel® Xeon® E5-x6xx v3 or later, E7-x8xx v3 or later Intel Xeon Bronze, Silver, Gold, or Platinum, AMD EPYC™ 7xx1 processors (Naples)
Supported Operating Systems	Linux® 64-bit OS RHEL 6.5, 6.6, 6.7, 6.8, 6.9, 7.0, 7.1, 7.2, 7.3, 7.4 SLES 11-SP4, 12, 12-SP1, 12-SP2 Fedora Core ver. 4 to 27; Open SuSe ver. 10 to 11 Ubuntu Server ver. 16.04 to 17.10; Debian 9.5.0 CentOS 4-7

### Hardware Specifications

Form-Factor / Interface	U.2 15mm, PCIe Gen3 AIC HH-HL
Power Requirement (DC +/-5%)	3.3V (aux) and 12V
Operating Power (typical)	25 watts active, 9 watts idle
Operating Temperature (ambient)	U.2: 0°C-70°C Ambient, AIC: 0°C-55°C Ambient
Endurance (PBW) <sup>3</sup>	1 TiB model: 19.1, 2 TiB model: 38.2, 4 TiB model: 78
Limited Warranty <sup>4</sup>	5 years

### Ordering Information

U.2 Part Number	Capacity	AIC Part Number	Capacity
OTS1741	1TiB	OTS1912	1TiB
OTS1742	2TiB	OTS1913	2TiB
OTS1743	4TiB	OTS1914	4TiB

<sup>1</sup> Memory capacity is indicated by GiB and TiB and based on binary values such that one gibibyte (GiB) is equal to 2<sup>30</sup> bytes and one tebibyte (TiB) is equal to 1024 GiB (2<sup>40</sup>) bytes. Storage capacity and endurance is indicated by TB and PB where one PB equals 1,000TB. Accessible capacity can vary from stated capacity due to software, formatting, and other factors.

<sup>2</sup> Suggested expansion of 8x DRAM based on internal performance testing across a variety of industry standard benchmarks.

<sup>3</sup> Endurance rating based on 4KiB random write workload.

<sup>4</sup> The warranty for the product will expire on the earlier of (i) the date when the flash media has reached one-erson (1%) of its remaining life or (ii) the expiration of the time period associated with the product.

\* Results will vary based on application and workload